

**Norsafe**

B E T T E R B Y D E S I G N



**Norsafe AS**

**Arendal, Norway**

# Applying SOLAS on High Speed Crafts

- Michel Saxlund, Sales Engineer at Norsafe Military and Professional
- Karl Marius Norschau, Industrial Designer with Norsafe Military and Professional

**Norsafe**

B E T T E R B Y D E S I G N

# History – Lifeboats



- Safety at Sea – Titanic 1912
- Conference in London 1913 – Convention for the Safety of Life at Sea (SOLAS)



**Norsafe**

B E T T E R B Y D E S I G N

# What is SOLAS?

- The International Convention for the Safety of Life at Sea (SOLAS)
- Ensures that ships flagged by them comply with minimum safety standards in construction, equipment and operation.
- The SOLAS international convention is administered by the International Maritime Organization (IMO)



# LSA according to different regulations

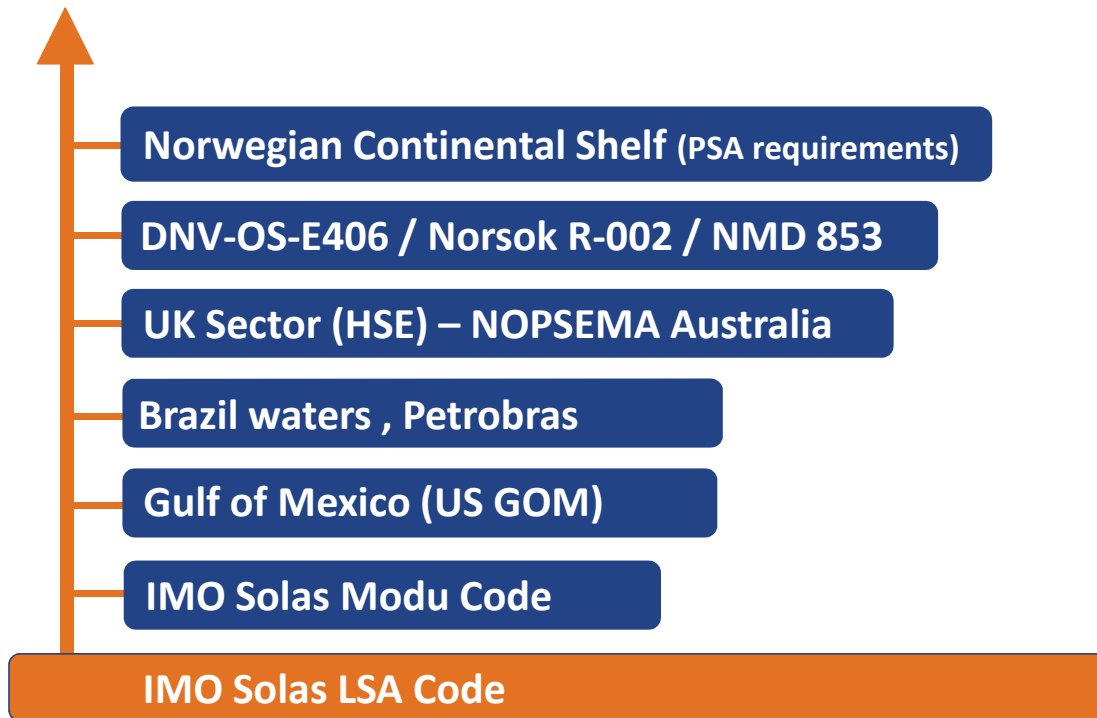

## Norsafe GES45 meets the DNV-OS-E406 standards

- GES45 tested for 9 hours
- In waves up to 11 meters
- Winds not below 30 meters pr. second



Harsh weather test of GES45

**Norsafe**

B E T T E R B Y D E S I G N

# Some LSA features on our boats

- Single point lifting gear
- Self-righting capabilities
- Engines stop at approx. 90deg. (engines can be started after capsizing)
- Run engine for min. 5 minutes out of water (in davit)
- Buoyant in damaged condition
- Fire retardant resin
- Impact and drop test



**Norsafe**

B E T T E R B Y D E S I G N

# Munin 1200 self-righting test





# Magnum 750 MKII fender and drop test

# Hull design

- Norsafe has a well proven deep-V hull design. Ranging from 6.5-12 meter hulls.
- Norsafe hulls are vacuum infused.
- All non stepped hulls are optimized for several different propulsion packages such as waterjet, stern drive or outboard.
- The Norsafe stepped hull technology is optimized for sterndrive, outboard and surface drive installations.
- Norsafe hull technology has evolved from year long research and development into GRP structures in freefall life boat systems.



# GES 52 world record drop from 66,8 meters



# CFD analysis

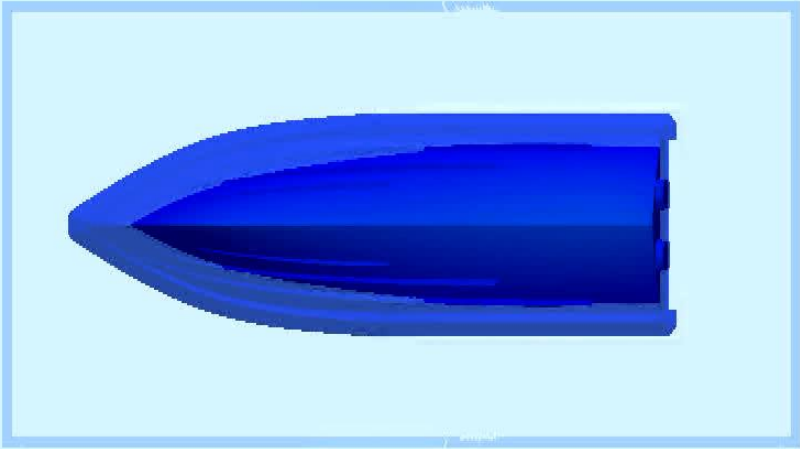

Pressure (Pa)

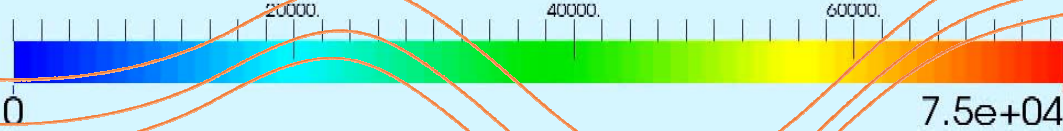

# Mission Specific Projects



# Integrated solutions

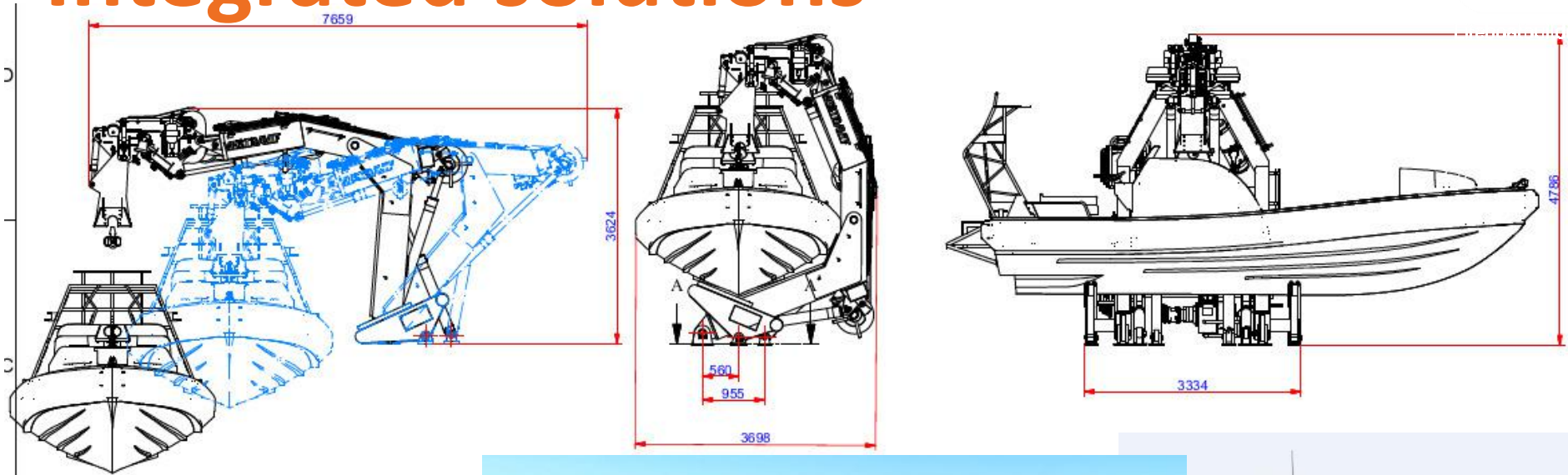

# Integrated solutions

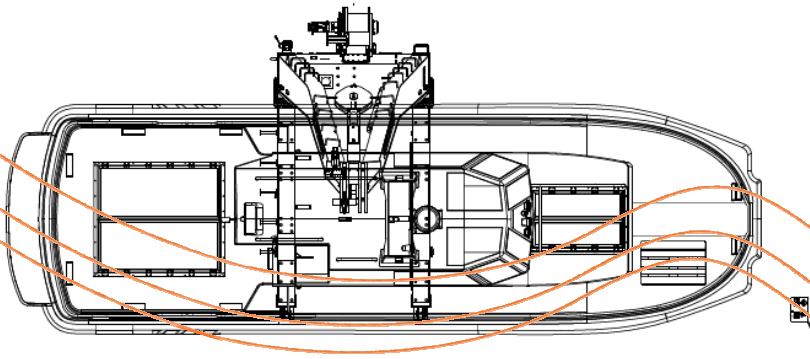
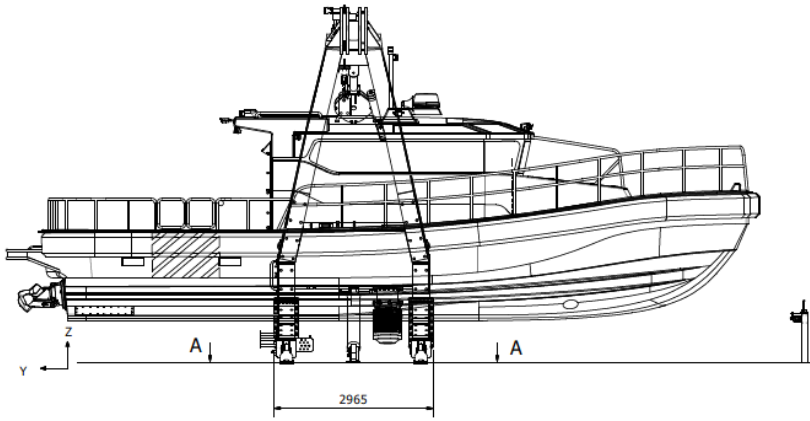





# Thank you for your attention

- Michel Saxlund, [Michel.Saxlund@norsafe.com](mailto:Michel.Saxlund@norsafe.com)
- Karl Marius Norschau, [Karl.Marius.Norschau@norsafe.com](mailto:Karl.Marius.Norschau@norsafe.com)
- For more info on our productrange please see [www.norsafe.com](http://www.norsafe.com)
- Feel free to follow us on social media.

