



Tactical Marine Operations Group ,

Royal Canadian Mounted Police

What are our challenges ?

What are the factors affecting mandates and mission sets of water born operations ?

- Canada has the longest coastline in the world at 243,042 kilometres.
- British Columbia alone is 26,000 kms. (The entire USA... 19,000)
- Vancouver is the 4th biggest port in North America and the biggest export port.
- The west coast has the largest ferry system in the western world and 2nd in the world.....Ridership of 25,000,000 per year



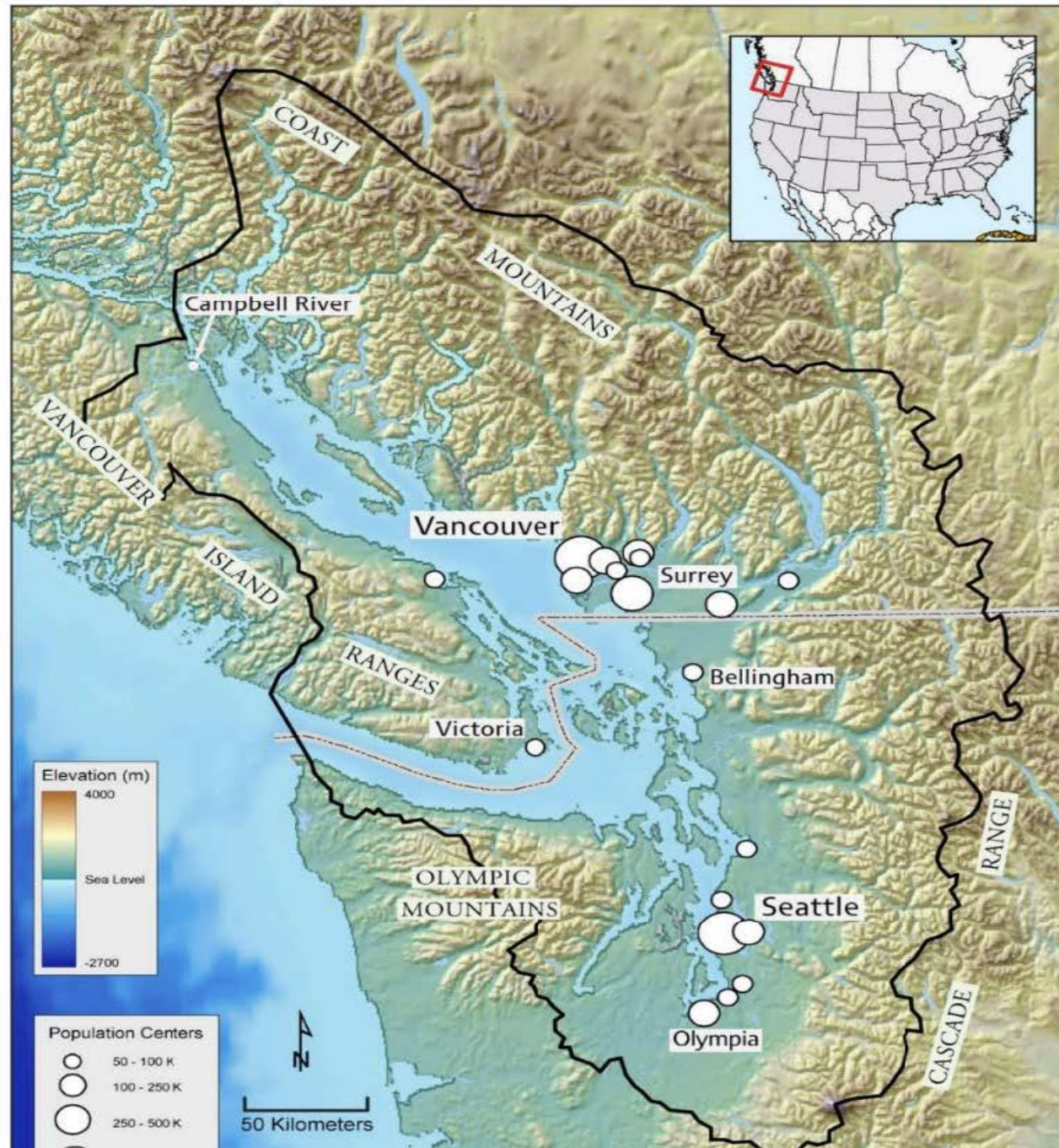

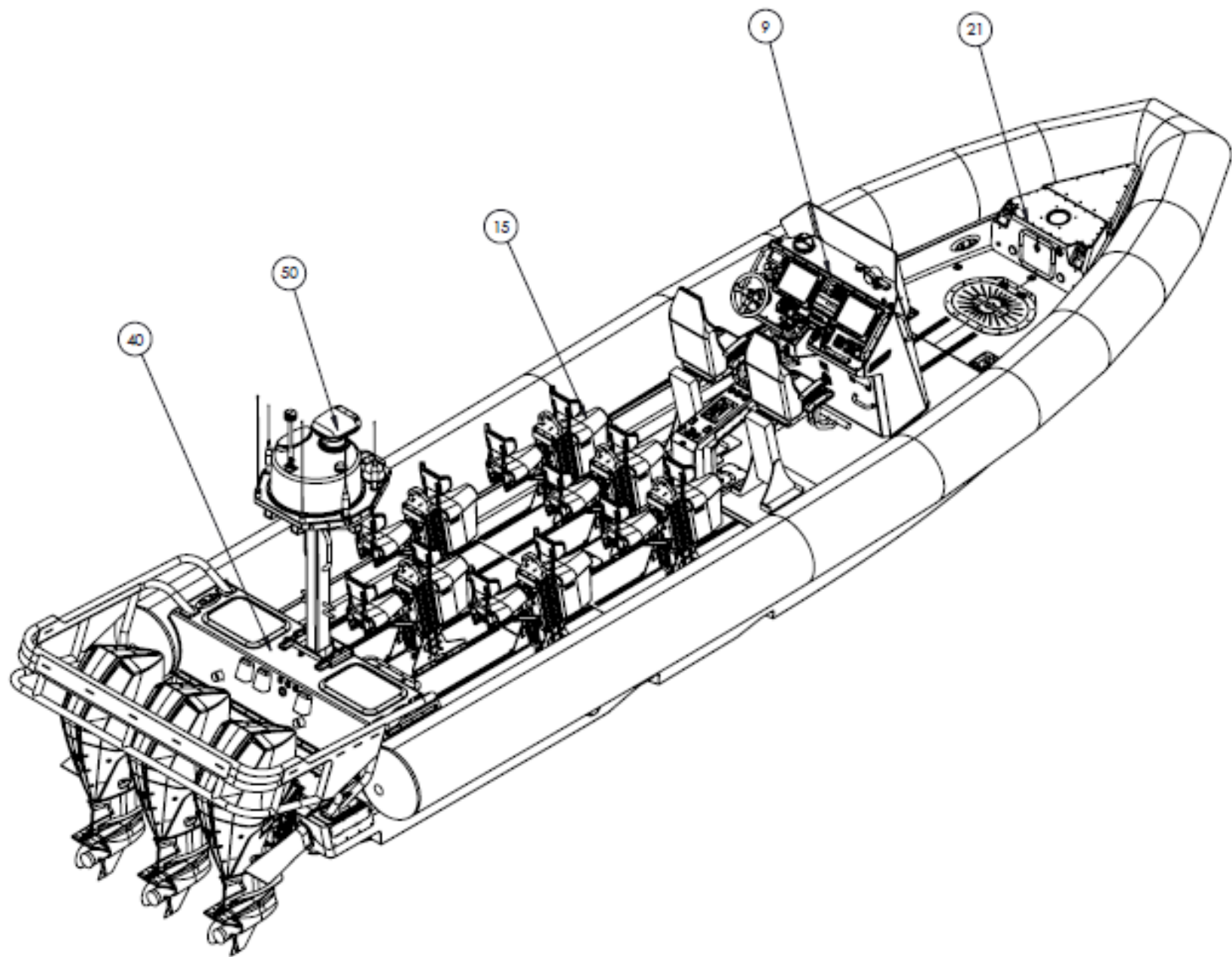





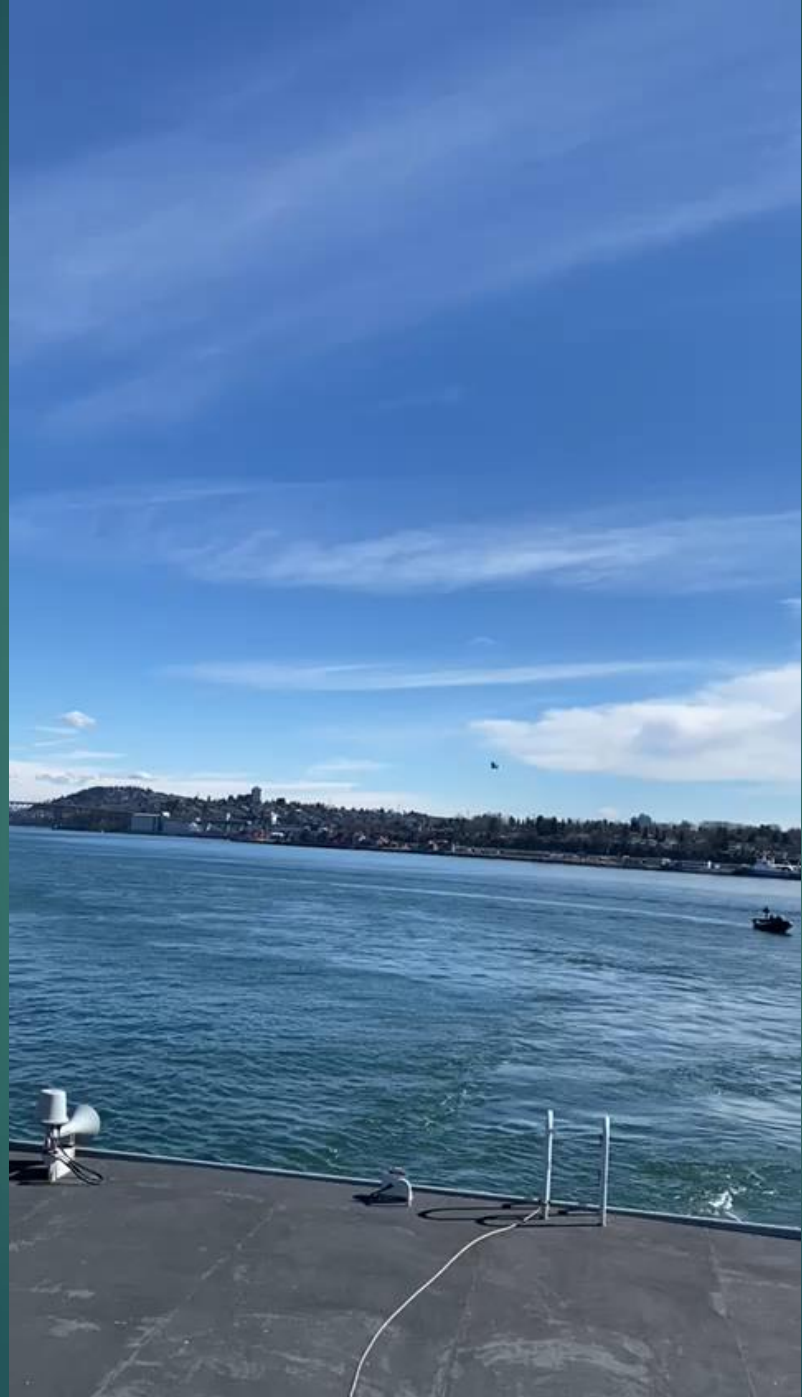







Challenges with cold weather operations and marine terrorism-

- ▶ The health of the operator and organizational ability to have that person function at an advanced level and complete high stress mission sets. (Working with USCG and Naval Special Warfare)
- ▶ On your worse day what as a team leader have we provided to the operators to guarantee success.
- ▶ To select a phenotype of person that will thrive in a challenging environment and will succumb to the stress of the job at an ameliorated rate. *(What is the secret to that? We all know "that" person)*

- 
1. How do we achieve a cultural change in our coxswains and the program ?
 2. How do we create a boat driver that the team has full confidence in ?
 3. How do create a defendable, measurable, and industry based course training standard ?
 4. How do we create an understudy program so “ on the day” our people our not only ready but are confident that they are ready?

Change in attitude and culture regarding being an officer on the water and not just in transporting SWAT teams.... Hard lessons learned by some very experienced officers.

Customs and Border Protection Agent Is Fatally Shot Off Puerto Rico

Two other agents were wounded in an exchange of gunfire with two people on a suspected smuggling vessel, an agency spokesman said. One of the people aboard the vessel was killed.



Customs and Border Protection said the vessel was 14 miles off Cabo Rojo, on Puerto Rico's southwest coast. Allison Dinner/Agence France-Presse — Getty Images



*Current Global
Situation*

9:43 54%

Sign in

The Guardian

Support us

News Opinion Sport Culture Lifestyle

World ▶ Europe US Americas Asia More

Russia

Danish reporters film armed men on guard as they approach alleged Russian spy ship - video



Public broadcasters of several Nordic countries have claimed Russia has established a state-run programme using spy ships disguised as fishing vessels in